

SVENSKA

NEDERLANDS

ESPAÑOL

ITALIANO

FRANÇAIS

DEUTSCH

ENGLISH



marantz[®] Integrated Amplifier
PM-KI-PEARL-LITE
PM7004

User Guide

SVENSKA

NEDERLANDS

ESPAÑOL

ITALIANO

FRANÇAIS

DEUTSCH

ENGLISH

☐ SAFETY PRECAUTIONS



CAUTION
RISK OF ELECTRIC SHOCK
DO NOT OPEN



CAUTION:
TO REDUCE THE RISK OF ELECTRIC SHOCK, DO NOT REMOVE COVER (OR BACK). NO USER-SERVICEABLE PARTS INSIDE. REFER SERVICING TO QUALIFIED SERVICE PERSONNEL.

The lightning flash with arrowhead symbol, within an equilateral triangle, is intended to alert the user to the presence of uninsulated "dangerous voltage" within the product's enclosure that may be of sufficient magnitude to constitute a risk of electric shock to persons.

The exclamation point within an equilateral triangle is intended to alert the user to the presence of important operating and maintenance (servicing) instructions in the literature accompanying the appliance.

WARNING:
TO REDUCE THE RISK OF FIRE OR ELECTRIC SHOCK, DO NOT EXPOSE THIS APPLIANCE TO RAIN OR MOISTURE.

IMPOTANT SAFETY INSTRUCTIONS

1. Read these instructions.
2. Keep these instructions.
3. Heed all warnings.
4. Follow all instructions.
5. Do not use this apparatus near water.
6. Clean only with dry cloth.
7. Do not block any ventilation openings. Install in accordance with the manufacturer's instructions.
8. Do not install near any heat sources such as radiators, heat registers, stoves, or other apparatus (including amplifiers) that produce heat.
9. Do not defeat the safety purpose of the polarized or grounding-type plug. A polarized plug has two blades with one wider than the other. A grounding type plug has two blades and a third grounding prong. The wide blade or the third prong are provided for your safety. If the provided plug does not fit into your outlet, consult an electrician for replacement of the obsolete outlet.
10. Protect the power cord from being walked on or pinched particularly at plugs, convenience receptacles, and the point where they exit from the apparatus.
11. Only use attachments/accessories specified by the manufacturer.
12. Use only with the cart, stand, tripod, bracket, or table specified by the manufacturer, or sold with the apparatus. When a cart is used, use caution when moving the cart/apparatus combination to avoid injury from tip-over.
13. Unplug this apparatus during lightning storms or when unused for long periods of time.
14. Refer all servicing to qualified service personnel. Servicing is required when the apparatus has been damaged in any way, such as power-supply cord or plug is damaged, liquid has been spilled or objects have fallen into the apparatus, the apparatus has been exposed to rain or moisture, does not operate normally, or has been dropped.
15. Batteries shall not be exposed to excessive heat such as sunshine, fire or the like.



Hot surface mark

CAUTION:
HOT SURFACE. DO NOT TOUCH.

The top surface over the internal heat sink may become hot when operating this product continuously. Do not touch hot areas, especially around the "Hot surface mark" and the top panel.

VORSICHT:

HEISSE OBERFLÄCHE. NICHT ANFASSEN.

Die Oberseite über dem inneren Kühlkörper könnte heiß werden, wenn dieses Produkt dauerhaft betrieben wird. Berühren Sie keine heißen Bereiche, hier besonders um die Kennzeichnung "Hot surface mark" und die Oberseite.

PRECAUTION:

SURFACE CHAUDE. NE PAS TOUCHER.

La surface supérieure du dissipateur de chaleur peut devenir chaude si vous utilisez ce produit en continu. Ne touchez pas les zones chaudes, tout particulièrement vers l'inscription "Hot surface mark" et le panneau supérieur.

ATTENZIONE:

SUPERFICIE CALDA. NON TOCCARE.

La superficie superiore al di sopra del dissipatore interno può riscaldarsi quando si adopera questo prodotto in maniera continuativa. Non toccare parti calde, in particolare quelle intorno alla dicitura "Hot surface mark" e al pannello superiore.

PRECAUCIÓN:
SUPERFICIE CALIENTE. NO TOCAR.

La superficie superior sobre el disipador de calor interno podría llegar a calentarse al operar este producto de forma continua. No toque las áreas calientes, especialmente las situadas alrededor de la "Hot surface mark" y del panel superior.

WAARSCHUWING:

HEET OPPERVLAK. NIET AANRAKEN.

Bij ononderbroken bediening van dit product kan het oppervlak boven de interne koelplaat heet worden. Raak het toestel niet aan waar het heet is, vooral niet in de buurt van het "Hot surface mark" en het bovenpaneel.

FÖRSIKTIGHETSMÅTT:

VARM YTA. RÖR EJ.

Ytan ovanför den interna kylflänsen kan bli varm när produkten används kontinuerligt. Rör inte varma områden. Var särskilt försiktig vid märkningen "Hot surface mark" och på topppanelen.

CAUTION:

To completely disconnect this product from the mains, disconnect the plug from the wall socket outlet. The mains plug is used to completely interrupt the power supply to the unit and must be within easy access by the user.

VORSICHT:

Um dieses Gerät vollständig von der Stromversorgung abzutrennen, ziehen Sie bitte den Stecker aus der Wandsteckdose. Der Netzstecker wird verwendet, um die Stromversorgung zum Gerät völlig zu unterbrechen; er muss für den Benutzer gut und einfach zu erreichen sein.

PRECAUTION:

Pour déconnecter complètement ce produit du courant secteur, débranchez la prise de la prise murale. La prise secteur est utilisée pour couper complètement l'alimentation de l'appareil et l'utilisateur doit pouvoir y accéder facilement.

ATTENZIONE:

Per scollegare completamente questo prodotto dalla rete di alimentazione elettrica, scollegare la spina dalla relativa presa a muro.

La spina di rete viene utilizzata per interrompere completamente l'alimentazione all'unità e deve essere facilmente accessibile all'utente.

PRECAUCIÓN:

Para desconectar completamente este producto de la alimentación eléctrica, desconecte el enchufe del enchufe de la pared. El enchufe de la alimentación eléctrica se utiliza para interrumpir por completo el suministro de alimentación eléctrica a la unidad y debe de encontrarse en un lugar al que el usuario tenga fácil acceso.

WAARSCHUWING:

Om de voeding van dit product volledig te onderbreken moet de stekker uit het stopcontact worden getrokken. De netstekker wordt gebruikt om de stroomtoevoer naar het toestel volledig te onderbreken en moet voor de gebruiker gemakkelijk bereikbaar zijn.

FÖRSIKTIGHETSMÅTT:

Koppla loss stickproppen från eluttaget för att helt skilja produkten från nätet. Stickproppen används för att helt bryta strömförsörjningen till apparaten, och den måste vara lättillgänglig för användaren.

ENGLISH

DEUTSCH

FRANÇAIS

ITALIANO

ESPAÑOL

NEDERLANDS

SVENSKA

☐ NOTE ON USE / HINWEISE ZUM GEBRAUCH / OBSERVATIONS RELATIVES A L'UTILISATION / NOTE SULL'USO / NOTAS SOBRE EL USO / ALVORENS TE GEBRUIKEN / OBSERVERA ANGÅENDE ANVÄNDNINGEN

WARNINGS	WARNHINWEISE	AVERTISSEMENTS	AVVERTENZE	ADVERTENCIAS	WAARSCHUWINGEN	VARNINGAR
<ul style="list-style-type: none"> • Avoid high temperatures. Allow for sufficient heat dispersion when installed in a rack. • Handle the power cord carefully. Hold the plug when unplugging the cord. • Keep the unit free from moisture, water, and dust. • Unplug the power cord when not using the unit for long periods of time. • Do not obstruct the ventilation holes. • Do not let foreign objects into the unit. • Do not let insecticides, benzene, and thinner come in contact with the unit. • Never disassemble or modify the unit in any way. • Ventilation should not be impeded by covering the ventilation openings with items, such as newspapers, tablecloths or curtains. • Naked flame sources such as lighted candles should not be placed on the unit. • Observe and follow local regulations regarding battery disposal. • Do not expose the unit to dripping or splashing fluids. • Do not place objects filled with liquids, such as vases, on the unit. • Do not handle the mains cord with wet hands. • When the switch is in the OFF position, the equipment is not completely switched off from MAINS. • The equipment shall be installed near the power supply so that the power supply is easily accessible. 	<ul style="list-style-type: none"> • Vermeiden Sie hohe Temperaturen. Beachten Sie, dass eine ausreichende Belüftung gewährleistet wird, wenn das Gerät auf ein Regal gestellt wird. • Gehen Sie vorsichtig mit dem Netzkaabel um. • Halten Sie das Kabel am Stecker, wenn Sie den Stecker herausziehen. • Halten Sie das Gerät von Feuchtigkeit, Wasser und Staub fern. • Wenn das Gerät längere Zeit nicht verwendet werden soll, trennen Sie das Netzkaabel vom Netzstecker. • Decken Sie den Lüftungsbereich nicht ab. • Lassen Sie keine fremden Gegenstände in das Gerät kommen. • Lassen Sie das Gerät nicht mit Insektiziden, Benzin oder Verdünnungsmitteln in Berührung kommen. • Versuchen Sie niemals das Gerät auseinander zu nehmen oder zu verändern. • Die Belüftung sollte auf keinen Fall durch das Abdecken der Belüftungsöffnungen durch Gegenstände wie beispielsweise Zeitungen, Tischtücher, Vorhänge o. Ä. behindert werden. • Auf dem Gerät sollten keinerlei direkte Feuerquellen wie beispielsweise angezündete Kerzen aufgestellt werden. • Bitte beachten Sie bei der Entsorgung der Batterien die örtlich geltenden Umweltbestimmungen. • Das Gerät sollte keiner tropfenden oder spritzenden Flüssigkeit ausgesetzt werden. • Auf dem Gerät sollten keine mit Flüssigkeit gefüllten Behälter wie beispielsweise Vasen aufgestellt werden. • Das Netzkaabel nicht mit feuchten oder nassen Händen anfassen. • Wenn der Schalter ausgeschaltet ist (OFF-Position), ist das Gerät nicht vollständig vom Stromnetz (MAINS) abgetrennt. • Das Gerät sollte in der Nähe einer Netzsteckdose aufgestellt werden, damit es leicht an das Stromnetz angeschlossen werden kann. 	<ul style="list-style-type: none"> • Eviter des températures élevées. • Tenir compte d'une dispersion de chaleur suffisante lors de l'installation sur une étagère. • Manipuler le cordon d'alimentation avec précaution. • Tenir la prise lors du débranchement du cordon. • Protéger l'appareil contre l'humidité, l'eau et la poussière. • Débrancher le cordon d'alimentation lorsque l'appareil n'est pas utilisé pendant de longues périodes. • Ne pas obstruer les trous d'aération. • Ne pas laisser des objets étrangers dans l'appareil. • Ne jamais démonter ou modifier l'appareil d'une manière ou d'une autre. • Ne pas recouvrir les orifices de ventilation avec des objets tels que des journaux, nappes ou rideaux. Cela entraverait la ventilation. • Ne jamais placer de flamme nue sur l'appareil, notamment des bougies allumées. • Veillez à respecter les lois en vigueur lorsque vous jetez les piles usagées. • L'appareil ne doit pas être exposé à l'eau ou à l'humidité. • Ne pas poser d'objet contenant du liquide, par exemple un vase, sur l'appareil. • Ne pas manipuler le cordon d'alimentation avec les mains mouillées. • Lorsque l'interrupteur est sur la position OFF, l'appareil n'est pas complètement déconnecté du SECTEUR (MAINS). • L'appareil sera installé près de la source d'alimentation, de sorte que cette dernière soit facilement accessible. 	<ul style="list-style-type: none"> • Evitate di esporre l'unità a temperature elevate. • Assicuratevi che vi sia un'adeguata dispersione del calore quando installate l'unità in un mobile per componenti audio. • Manneggiate il cavo di alimentazione con attenzione. • Tenete ferma la spina quando scollegate il cavo dalla presa. • Tenete l'unità lontana dall'umidità, dall'acqua e dalla polvere. • Scollegate il cavo di alimentazione quando prevedete di non utilizzare l'unità per un lungo periodo di tempo. • Non coprite i fori di ventilazione. • Non inserite corpi estranei all'interno dell'unità. • Assicuratevi che l'unità non entri in contatto con insetticidi, benzolo o solventi. • Non smontate né modificate l'unità in alcun modo. • Le aperture di ventilazione non devono essere ostruite coprendole con oggetti, quali giornali, tovaglie, tende e così via. • Non posizionate sull'unità fi amme libere, come ad esempio candele accese. • Prestate attenzione agli aspetti legati alla tutela dell'ambiente nello smaltimento delle batterie. • L'apparecchiatura non deve essere esposta a gocciolii o spruzzi. • Non posizionate sull'unità alcun oggetto contenente liquidi, come ad esempio i vasi. • Non toccare il cavo di alimentazione con le mani bagnate. • Quando l'interruttore è nella posizione OFF, l'apparecchiatura non è completamente scollegata da MAINS. • L'apparecchio va installato in prossimità della fonte di alimentazione, in modo che quest'ultima sia facilmente accessibile. 	<ul style="list-style-type: none"> • Evite altas temperaturas. Permite la suficiente dispersión del calor cuando está instalado en la consola. • Maneje el cordón de energía con cuidado. • Sostenga el enchufe cuando desconecte el cordón de energía. • Mantenga el equipo libre de humedad, agua y polvo. • Desconecte el cordón de energía cuando no utilice el equipo por mucho tiempo. • No obstruya los orificios de ventilación. • No deje objetos extraños dentro del equipo. • No permita el contacto de insecticidas, gasolina y diluyentes con el equipo. • No cubra los agujeros de ventilación. • No permita el contacto de insecticidas, gasolina y diluyentes con el equipo. • No inserte cuerpos extraños al interior de la unidad. • La ventilación no debe quedar obstruida por haberse cubierto las aperturas con objetos como periódicos, manteles o cortinas. • No deberán colocarse sobre el aparato fuentes inflamables sin protección, como velas encendidas. • A la hora de deshacerse de las pilas, respete la normativa para el cuidado del medio ambiente. • No exponer el aparato al goteo o salpicaduras cuando se utilice. • No colocar sobre el aparato objetos llenos de líquido, como jarros. • No maneje el cable de alimentación con las manos mojadas. • Cuando el interruptor está en la posición OFF, el equipo no está completamente desconectado de la alimentación MAINS. • El equipo se instalará cerca de la fuente de alimentación de manera que resulte fácil acceder a ella. 	<ul style="list-style-type: none"> • Vermijd hoge temperaturen. Zorg er bij installatie in een audiorack voor, dat de door het toestel geproduceerde warmte goed kan worden afgevoerd. • Hankeer het netsnoer voorzichtig. • Houd het snoer bij de stekker vast wanneer deze moet worden aan- of losgekoppeld. • Laat geen vochtigheid, water of stof in het apparaat binnendringen. • Neem altijd het netsnoer uit het stopcontact wanneer het apparaat gedurende een lange periode niet wordt gebruikt. • De ventilatieopeningen mogen niet worden geblokkeerd. • Laat geen vreemde voorwerpen in dit apparaat vallen. • Voorkom dat insecticiden, benzene of verfverdunder met dit toestel in contact komen. • Dit toestel mag niet gedemonteerd of aangepast worden. • De ventilatie mag niet worden belemmerd door de ventilatieopeningen af te dekken met bijvoorbeeld kranten, een tafelkleed of gordijnen. • Plaats geen open vlammen, bijvoorbeeld een brandende kaars, op het apparaat. • Houd u steeds aan de milieuvoorschriften wanneer u gebruikte batterijen wegdoet. • Stel het apparaat niet bloot aan druppels of spatten. • Plaats geen voorwerpen gevuld met water, bijvoorbeeld een vaas, op het apparaat. • Raak het netsnoer niet met natte handen aan. • Als de schakelaar op OFF staat, is het apparaat niet volledig losgekoppeld van de netspanning (MAINS). • De apparatuur wordt in de buurt van het stopcontact geïnstalleerd, zodat dit altijd gemakkelijk toegankelijk is. 	<ul style="list-style-type: none"> • Undvik höga temperaturer. Se till att det finns möjlighet till god värmeavledning vid montering i ett rack. • Hantera nätkabeln varsamt. Håll i kabeln när den kopplas från el-uttaget. • Utsätt inte apparaten för fukt, vatten och damm. • Koppla loss nätkabeln om apparaten inte kommer att användas i lång tid. • Täpp inte till ventilationsöppningarna. • Se till att främmande föremål inte tränger in i apparaten. • Se till att inte insektsmedel på spraybruk, bensin och thinner kommer i kontakt med apparatens hölje. • Ta inte isär apparaten och försök inte bygga om den. • Ventilationen bör inte förhindras genom att täcka för ventilationsöppningarna med föremål såsom tidningar, bordsdukar eller gardiner. • Placera inte öppen eld, t.ex. tända ljus, på apparaten. • Tank på miljöaspekterna när du bortskaffar batterier. • Apparaten får inte utsättas för vätska. • Placera inte föremål fyllda med vätska, t.ex. vasar, på apparaten. • Hantera inte nätsladden med våta händer. • Även om strömbrytaren står i det avstängda läget OFF, så är utrustningen inte helt bortkopplad från det elektriska nätet (MAINS). • Utrustningen ska vara installerad nära strömuttaget så att strömförsörjningen är lätt att tillgå.

SVENSKA

NEDERLANDS

ESPAÑOL

ITALIANO

FRANÇAIS

DEUTSCH

ENGLISH

• DECLARATION OF CONFORMITY

We declare under our sole responsibility that this product, to which this declaration relates, is in conformity with the following standards: EN60065, EN55013, EN55020, EN61000-3-2 and EN61000-3-3. Following the provisions of Low Voltage Directive 2006/95/EC and EMC Directive 2004/108/EC, the EC regulation 1275/2008 and its frame work Directive 2009/125/EC for Energy-related Products (ErP).

• ÜBEREINSTIMMUNGSEKTLÄRUNG

Wir erklären unter unserer Verantwortung, daß dieses Produkt, auf das sich diese Erklärung bezieht, den folgenden Standards entspricht: EN60065, EN55013, EN55020, EN61000-3-2 und EN61000-3-3. Following the provisions of low voltage directive 2006/95/EC and EMC directive 2004/108/EC, the EC regulation 1275/2008 and its frame work directive 2009/125/EC for energy-related products (ErP).

• DECLARATION DE CONFORMITE

Nous déclarons sous notre seule responsabilité que l'appareil, auquel se réfère cette déclaration, est conforme aux standards suivants: EN60065, EN55013, EN55020, EN61000-3-2 et EN61000-3-3. Selon la directive 2006/95/EC concernant la basse tension et la directive CEM 2004/108/EC, la réglementation européenne 1275/2008 et la directive 2009/125/EC établissant un cadre de travail applicable aux produits liés à l'énergie (ErP).

• DICHIARAZIONE DI CONFORMITÀ

Dichiaro con piena responsabilità che questo prodotto, al quale la nostra dichiarazione si riferisce, è conforme alle seguenti normative: EN60065, EN55013, EN55020, EN61000-3-2 e EN61000-3-3. Facendo seguito alle disposizioni della direttiva sul basso voltaggio 2006/95/EC alla direttiva EMC 2004/108/EC, alla norma EC 1275/2008 e alla relativa legge quadro 2009/125/EC in materia di prodotti alimentati ad energia (ErP). QUESTO PRODOTTO E' CONFORME AL D.M. 28/08/95 N. 548

• DECLARACIÓN DE CONFORMIDAD

Declaramos bajo nuestra exclusiva responsabilidad que este producto al que hace referencia esta declaración, está conforme con los siguientes estándares: EN60065, EN55013, EN55020, EN61000-3-2 y EN61000-3-3. De acuerdo con la directiva sobre baja tensión 2006/95/CE y la directiva sobre CEM 2004/108/CE, la normativa CE 1275/2008 y su directiva marco 2009/125/EC para productos relacionados con la energía (ErP).

• EENVORMIGHEIDSVKLRING

Wij verklaren uitsluitend op onze verantwoordelijkheid dat dit produkt, waarop deze verklaring betrekking heeft, in overeenstemming is met de volgende normen: EN60065, EN55013, EN55020, EN61000-3-2 en EN61000-3-3. Volgens de voorzieningen van lage spanningsrichtlijn 2006/95/EC en EMC-richtlijn 2004/108/EC, de EU-richtlijn 1275/2008 en de kaderrichtlijn 2009/125/EC voor energieverbruikende producten (ErP).

• ÖVERENSSTÄMMELSESINTYG

Härmed intygas helt på eget ansvar att denna produkt, vilken detta intyg avser, uppfyller följande standarder: EN60065, EN55013, EN55020, EN61000-3-2 och EN61000-3-3. Uppfyller reglerna i lågspänningsdirektivet 2006/95/EC och EMC-direktivet 2004/108/EC, EU-förordningen 1275/2008 och ramverketsdirektivet 2009/125/EC för energirelaterade produkter (ErP).

Marantz Europe
A division of D&M Europe B.V.
Beemdstraat 11, 5653 MA Eindhoven,
The Netherlands

A NOTE ABOUT RECYCLING:

This product's packaging materials are recyclable and can be reused. Please dispose of any materials in accordance with the local recycling regulations. When discarding the unit, comply with local rules or regulations. Batteries should never be thrown away or incinerated but disposed of in accordance with the local regulations concerning battery disposal. This product and the supplied accessories, excluding the batteries, constitute the applicable product according to the WEEE directive.

HINWEIS ZUM RECYCLING:

Das Verpackungsmaterial dieses Produktes ist zum Recyceln geeignet und kann wieder verwendet werden. Bitte entsorgen Sie alle Materialien entsprechend der örtlichen Recycling-Vorschriften. Beachten Sie bei der Entsorgung des Gerätes die örtlichen Vorschriften und Bestimmungen. Die Batterien dürfen nicht in den Hausmüll geworfen oder verbrannt werden; bitte entsorgen Sie die Batterien gemäß der örtlichen Vorschriften. Dieses Produkt und das im Lieferumfang enthaltene Zubehör (mit Ausnahme der Batterien!) entsprechen der WEEE-Direktive.

UNE REMARQUE CONCERNANT LE RECYCLAGE:

Les matériaux d'emballage de ce produit sont recyclables et peuvent être réutilisés. Veuillez disposer des matériaux conformément aux lois sur le recyclage en vigueur.

Lorsque vous mettez cet appareil au rebut, respectez les lois ou réglementations en vigueur. Les piles ne doivent jamais être jetées ou incinérées, mais mises au rebut conformément aux lois en vigueur sur la mise au rebut des piles. Ce produit et les accessoires inclus, à l'exception des piles, sont des produits conformes à la directive DEEE.

NOTA RELATIVA AL RICICLAGGIO:

I materiali di imballaggio di questo prodotto sono riutilizzabili e riciclabili. Smaltire i materiali conformemente alle normative locali sul riciclaggio. Per lo smaltimento dell'unità, osservare le normative o le leggi locali in vigore. Non gettare le batterie, né incenerirle, ma smaltirle conformemente alla normativa locale sui rifiuti chimici. Questo prodotto e gli accessori inclusi nell'imballaggio sono applicabili alla direttiva RAEE, ad eccezione delle batterie.

ACERCA DEL RECICLAJE:

Los materiales de embalaje de este producto son reciclables y se pueden volver a utilizar. Disponga de estos materiales siguiendo los reglamentos de reciclaje de su localidad. Cuando se deshaga de la unidad, cumpla con las reglas o reglamentos locales. Las pilas nunca deberán tirarse ni incinerarse. Deberá disponer de ellas siguiendo los reglamentos de su localidad relacionados con los desperdicios químicos. Este producto junto con los accesorios empaquetados es el producto aplicable a la directiva RAEE excepto pilas.

EEN AANTEKENING MET BETREKKING TOT DE RECYCLING:

Het inpakmateriaal van dit product is recycleerbaar en kan opnieuw gebruikt worden. Er wordt verzocht om zich van elk afvalmateriaal te ontdoen volgens de plaatselijke voorschriften. Volg voor het wegdoen van de speler de voorschriften voor de verwijdering van wit- en bruingoed op.

Batterijen mogen nooit worden weggegooid of verbrand, maar moeten volgens de plaatselijke voorschriften betreffende chemisch afval worden verwijderd. Op dit product en de meegeleverde accessoires, m.u.v. de batterijen is de richtlijn voor afgedankte elektrische en elektronische apparaten (WEEE) van toepassing.

OBSERVERA ANGÅENDE ÅTERVINNING:

Produktens emballage är återvinningsbart och kan återanvändas. Kassera det enligt lokala återvinningsbestämmelser. När du kasserar enheten ska du göra det i överensstämmelse med lokala regler och bestämmelser. Batterier får absolut inte kastas i soporna eller brännas. Kassera dem enligt lokala bestämmelser för kemiskt avfall. Denna apparat och de tillbehör som levereras med den uppfyller gällande WEEE-direktiv, med undantag av batterierna.



CAUTIONS ON INSTALLATION
VORSICHTSHINWEISE ZUR AUFSTELLUNG
PRÉCAUTIONS D'INSTALLATION
PRECAUZIONI SULL'INSTALLAZIONE
EMPLAZAMIENTO DE LA INSTALACIÓN
VOORZORGSMAATREGELEN BIJ DE
INSTALLATIE
FÖRSIKTIGHET VID INSTALLATIONEN

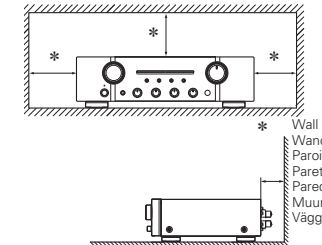

- * **For proper heat dispersal, do not install this unit in a confined space, such as a bookcase or similar enclosure.**
 - More than 0.3 m is recommended.
 - Do not place any other equipment on this unit.
- * **Stellen Sie das Gerät nicht an einem geschlossenen Ort, wie in einem Bücherregal oder einer ähnlichen Einrichtung auf, da dies eine ausreichende Belüftung des Geräts behindern könnte.**
 - Empfohlen wird über 0,3 m.
 - Keine anderen Gegenstände auf das Gerät stellen.
- * **Pour permettre la dissipation de chaleur requise, n'installez pas cette unité dans un espace confiné tel qu'une bibliothèque ou un endroit similaire.**
 - Une distance de plus de 0,3 m est recommandée.
 - Ne placez aucun matériel sur cet appareil.
- * **Per una dispersione adeguata del calore, non installare questa apparecchiatura in uno spazio ristretto, come ad esempio una libreria o simil.**
 - Si raccomanda una distanza superiore ai 0,3 m.
 - Non posizionare alcun altro oggetto o dispositivo su questo dispositivo.
- * **Para la dispersión del calor adecuadamente, no instale este equipo en un lugar confinado tal como una librería o unidad similar.**
 - Se recomienda dejar más de 0,3 m alrededor.
 - No coloque ningún otro equipo sobre la unidad.
- * **Plaats dit toestel niet in een kleine afgesloten ruimte, zoals een boekenkast e.d., omdat anders de warmte niet op gepaste wijze kan worden afgevoerd.**
 - Meer dan 0,3 m is aanbevolen.
 - Plaats geen andere apparatuur op het toestel.
- * **För att tillförsäkra god värmeavledning får utrustningen inte installeras i instängda utrymmen, som t.ex. en bokhylla eller liknande.**
 - Mer än 0,3 m rekommenderas.
 - Placera ingen annan utrustning ovanpå den här enheten.

ИНТЕГРИРОВАННЫЙ УСИЛИТЕЛЬ

Marantz PM-KI-PEARL-LITE/PM7004 АЯ 46
(РУКОВОДСТВО ПО ЭКСПЛУАТАЦИИ)



Вы приобрели устройство усилительное/преобразовательное производства компании "D&M Холдингс Инк", Япония ("D&M Holdings Inc.", Japan). Модель PM KI PEARL LITE/PM7004 является интегрированным усилителем и предназначена для усиления аудиосигналов в домашних аудиосистемах. Это изделие широко известно в кругах истинных ценителей высококлассного звука. Качество и безопасность подтверждены множеством тестов, проведенных как зарубежными, так и российскими испытательными лабораториями.

Изготовитель в течение 3 лет (срок службы) после выпуска данного изделия обеспечивает наличие комплектующих в целях возможности проведения ремонта и технического обслуживания, по истечении которого эксплуатация и техническое обслуживание продолжается в соответствии с действующими нормативными документами. Изделие остается безопасным для жизни, здоровья человека и окружающей среды в течение всего срока эксплуатации. Гарантийный срок 1 год.

Информация о Российской сертификации

Но сертификата соответствия	Орган по сертификации	Нормативные документы	Наименование сертифицированной продукции	Срок действия сертификата
РОСС JPAЯ46.B13676	РОСТЕСТ МОСКВА	ГОСТ Р МЭК 60065 2005 ГОСТ 22505 97 ГОСТ Р 51515 99 ГОСТ Р 51317.3.2 2006 ГОСТ Р 51317.3.3 2008	Устройства усилительные/ преобразовательные	До 16.03.2013

Основные технические характеристики

См. в конце инструкции

ВНИМАНИЕ: Если Вы приобрели аудиоаппаратуру надлежащего качества, то, по Российским законам, она не подлежит возврату или обмену на аналогичный товар других размера, формы и т.д.

D&M Холдингс Инк
Здание D&M, 2 1 Ниссин тё
Кавасаки ку, Кавасаки си, Канагава
2108569, Япония

D&M Holdings Inc.
D&M Building, 2 1 Nisshin Cho
Kawasaki Ku, Kawasaki Shi, Kanagawa
2108569, Japan

Getting started

Thank you for purchasing this MARANTZ product. To ensure proper operation, please read this owner's manual carefully before using the product. After reading the manual, be sure to keep it for future reference.

Contents

Getting started	1
Accessories	1
About this manual	1
Main features	2
Features of the PM7004 and PM-KI-PEARL-LITE	2
Features of the PM-KI-PEARL-LITE	2
Cautions on handling	3
About the remote control	3
Inserting the batteries	3
Operating range of the remote control	3
Part names and functions	4
Front panel	4
Rear panel	4
Remote control	5
Basic connections	6
Preparations	6
Connecting cables	6
Connecting the audio equipment	6
Connecting the speakers	6
Connecting the speakers cables	6
Speaker connections	7
Connecting players	7
Connecting recorders	7
Connecting the power cord	8
Basic operation	8
Before use	8
Turning the power on	8
Turning the power standby	8
Turning the power off	8
Starting playback	9
Direct playback using a source audio component	9
Muting sound	9
Using headphone set	9
Starting Recording	9
Advanced connections	9
Connecting P.DIRECT connectors	9
Connecting pre out connectors	10
Connecting the remote control connectors	10
Advanced operations	10
Setting Auto standby mode	10
Troubleshooting	11
Specifications	12
Explanation terms	12
Index	12



Basic operation	8
Before use	8
Turning the power on	8
Turning the power standby	8
Turning the power off	8
Starting playback	9
Direct playback using a source audio component	9
Muting sound	9
Using headphone set	9
Starting Recording	9
Advanced connections	9
Connecting P.DIRECT connectors	9
Connecting pre out connectors	10
Connecting the remote control connectors	10
Advanced operations	10
Setting Auto standby mode	10
Troubleshooting	11
Specifications	12
Explanation terms	12
Index	12

Accessories

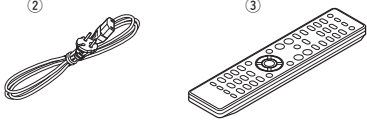
Check that the following parts are supplied with the product.

- ① Owner's manual 1
 - ② Power cord (Cord length: Approx. 1.8 m) 1
 - ③ Remote control (RC003PM) 1
 - ④ R03/AAA batteries 2
- 

About this manual

- Operation buttons**
 The operations described in this manual are based mainly on remote control operation.
- Symbols**
 -  This symbol indicates a reference page on which related information is described.
 -  This symbol indicates a supplementary information and tips for operations.
 - NOTE** This symbol indicates points to remember operations or function limitations.
- Illustrations**
 Note that the illustrations in these instructions are for explanation purposes and may differ from the actual unit.

Getting started
Basic connections
Basic operation
Advanced connections
Advanced operation
Troubleshooting
Specifications
Explanation terms
Index

Main features

Features of the PM7004 and PM-KI-PEARL-LITE

Tri-tone control

This unit has a 3-tone control function for adjusting the midrange sound in addition to the bass and treble sounds so that you can make a more variable sound adjustment according to source and system.

All-discrete current-feedback amplifier

Marantz' proprietary current-feedback circuit, using discrete components, is adopted in the pre amplifier and power amplifier. It is a high-speed amplifier using the latest technology developed for the higher-grade amplifiers.

HDAM-SA3 Technology

The V/I converter circuit, which is the key block of the current-feedback pre-amplifier and power amplifier, is equivalent to the HDAM-SA3 ampmodule developed for such higher-grade models as the PM-11S2.

CD direct buffer amplifier

An input buffer amplifier exclusive for CD is mounted near the CD input jacks. This is a high-speed buffer amplifier made with discrete components, which avoids interference between right and left channels and can send the signals to the pre-amplifier with very high fidelity.

Improved momentary current supply ability

It is generally known that the sound quality is not necessarily the same even if amplifiers have the same specifications. Marantz considers the cause to be the power to drive speakers. The power amplifier of this unit has the ability to momentarily supply current of 25 A or more to drive speakers strongly.

Short-power-line layout

For strong momentary current supply, a short power-line layout unifies the power circuit and output stage of the power amplifier section.

This layout allows connecting the large-current lines via the shortest route while to arranging the left and right channels symmetrically.

Features of the PM-KI-PEARL-LITE

All-Discrete current-feedback phono equalizer

As a phono equalizer amplifier for MM cartridges, a constant current-feedback PHONO equalizer of quality equal to that of the higher-grade model PM-11S2 is used.

Double-shielded triodal transformer

The unit is equipped with a toroidal power transformer to minimize vibration and leakage flux specific to the transformer. Especially to reduce leakage flux, which affects sound quality, the periphery is double-shielded, using a core ring and a short ring.

Block condenser of large capacity

A large-capacity condenser of 18,000 μ F is used in the power circuit of the power amplifier. In the preamplifier, a 4700 μ F condenser is used.

High-performance volume

Capacitor for high quality sound

Double-layered and Copper-finished chassis

High-grade speaker terminals

Cautions on handling

- **Before turning the power switch on**
Check once again that all connections are correct and that there are no problems with the connection cables.
- Power is supplied to some of the circuitry even when the unit is set to the standby mode. When leaving home for long periods of time, be sure to unplug the power cord from the power outlet.
- **About condensation**
If there is a major difference in temperature between the inside of the unit and the surroundings, condensation may form on parts inside the unit, causing the unit to fail to operate properly. If this happens, let the unit sit for an hour or two with the power off and wait until there is little difference in temperature before using the unit.
- **Cautions on using mobile phones**
Using a mobile phone near this unit may result in noise. If that occurs, move the mobile phone away from the unit when it is in use.
- **Moving the unit**
Turn off the power and unplug the power cord from the power outlet. Next, disconnect the cables connected to other system units before moving the unit.

About the remote control

Inserting the batteries

- ① Remove the rear cover of the remote control.
- ② Set two R03/AAA batteries in the battery compartment in the indicated direction.
- ③ Put the rear cover back on.

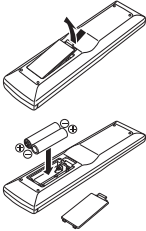

NOTE

- Replace the batteries with new ones if the unit does not operate even when the remote control is operated close to the unit.
- The supplied batteries are only for verifying operation.
- Insert the batteries in the proper direction, following the “⊕” and “⊖” marks in the battery compartment.
- To prevent damage or leakage of battery fluid:
 - Do not use a new battery with an old one.
 - Do not use two different types of batteries.
 - Do not attempt to charge dry batteries.
- Do not short-circuit, disassemble, heat or dispose of batteries in a fire.
- Do not keep the battery in a place exposed to direct sunlight or in places with extremely high temperatures, such as near a heater.
- If the battery fluid leaks, carefully wipe the fluid off the inside of the battery compartment and insert new batteries.
- Remove the batteries from the remote control if it will not be used for a long time.
- Used batteries in accordance with local regulations on battery disposal.

Operating range of the remote control

operate the remote control while pointing it at the remote sensor.

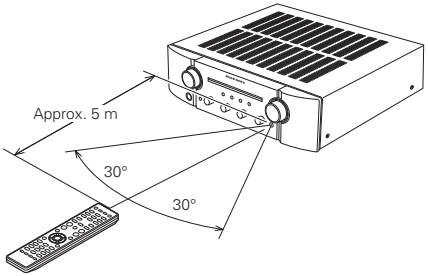

NOTE

The unit may function improperly or the remote control may not operate if the remote control sensor is exposed to direct sunlight, or strong artificial light from a fluorescent or infrared light.

- Getting started
- Basic connections
- Basic operation
- Advanced connections
- Advanced operation
- Troubleshooting
- Specifications
- Explanation terms
- Index

Part names and functions

For buttons not explained here, see the page indicated in parentheses ().

Front panel

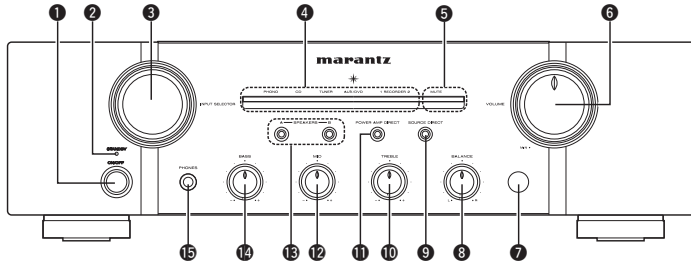

- | | |
|--|--|
| 1 Power switch (ON/OFF)..... (8) | 12 MID control knob..... (8, 9) |
| 2 STANDBY indicator..... (8) | 13 SPEAKERS A/B switch/indicators..... (9) |
| Indicates the status of the unit's as follows: | |
| • Power "ON" : Off | |
| • When the protection circuit is activated : | |
| Red (blinking)..... (6) | |
| • Standby : Red | |
| • Power "OFF" : Off | |
| 3 INPUT SELECTOR knob..... (9) | 14 BASS control knob..... (8, 9) |
| 4 Input indicators..... (8) | 15 Headphone jack (PHONES)..... (9) |
| 5 MUTE indicator (MUTE)..... (9) | |
| 6 VOLUME control knob..... (8, 9) | |
| 7 Remote control sensor..... (3, 10) | |
| 8 BALANCE control knob..... (8, 9) | |
| 9 SOURCE DIRECT switch/indicator..... (9) | |
| 10 TREBLE control knob..... (8, 9) | |
| 11 POWER AMP DIRECT switch/indicator..... (9) | |

NOTE

You can adjust the 8 BALANCE, 10 TREBLE, 12 MID and 14 BASS control knobs only when SOURCE DIRECT switch is turned off.

Rear panel

PM-KI-PEARL-LITE

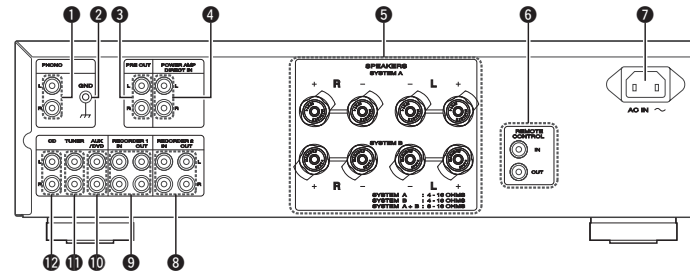

PM7004

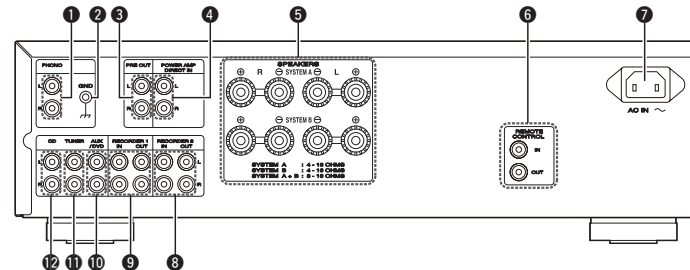

- | | |
|--|---|
| 1 PHONO input connectors..... (7) | 7 AC inlet (AC IN)..... (8) |
| 2 PHONO GND terminal..... (7) | 8 RECORDER 2 input/output connectors..... (7) |
| 3 PRE OUT connectors..... (10) | 9 RECORDER 1 input/output connectors..... (7) |
| 4 POWER AMP DIRECT IN connectors..... (9) | 10 AUX/DVD input connectors..... (7) |
| 5 Speaker system terminals (SPEAKERS SYSTEM A/B)..... (6, 7) | 11 TUNER input connectors..... (7) |
| 6 REMOTE CONTROL input/output connectors..... (10) | 12 CD input connectors..... (7) |

Remote control

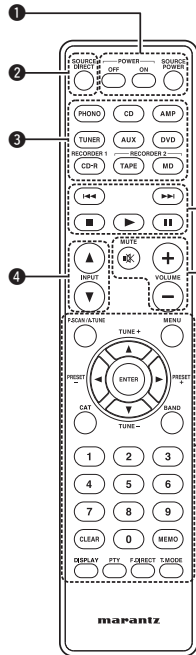

You can use the supplied remote control to operate this unit and Marantz audio components such as CD players, tuners, DVD players, and tape decks. See "Operating Marantz audio components" (page 5).

- 1 POWER ON/STANDBY buttons** (8)
 - POWER ON button
 - POWER OFF button
 - SOURCE POWER button

You can press this button to switch the mode of Marantz audio components (provided with a power standby function) between power-on and standby.
- 2 SOURCE DIRECT button** (9)
- 3 Input selector buttons** (5)
- 4 INPUT ▲/▼ buttons** (9)
- 5 Component operating buttons**
- 6 VOLUME adjustment buttons** (8, 9)
 - MUTE Button
 - VOLUME + / - Button

Operating Marantz audio components

Operation

- 1 Press the corresponding **3** Input selector button of the audio component for selecting the input source to be used in playback and recording.
 - The remote control operation is switched to operation mode of the selected input source.
 - This unit's function will be switched accordingly.
- 2 Operate the audio component.
 - See the table on the right for the buttons you can use.



- The remote control **3** Input selector buttons are used to select the input source for this unit and switch the remote control operation mode at the same time.
- You can operate the remote control of this unit regardless of the remote control mode setting.
- To use the remote control correctly, also refer to the operating instructions of other components.

NOTE

Some input terminals of this unit and corresponding input selector buttons on the remote control have different names, as shown below.

Remote control buttons	The unit input terminals
AUX, DVD	AUX/DVD
CD-R	RECORDER1
TAPE, MD	RECORDER2

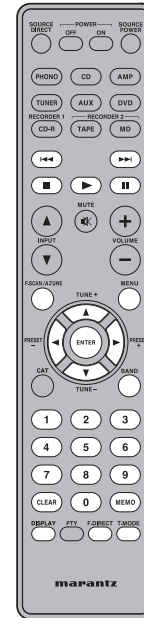

CD operation

Operation buttons	Function
⏮ ⏭	Skip
■	Stop
▶	Playback
⏸	Pause
0 - 9	Track selection
T.MODE	Sound mode selection

DVD operation

Operation buttons	Function
⏮ ⏭	Skip
■	Stop
▶	Playback
⏸	Pause
MENU	Menu
▲ ▼ ◀ ▶	Cursor operation
ENTER	Enter setting
0 - 9	Enter number
DISPLAY	Display disc information

Tuner operation

Operation buttons	Function
P.SCAN/A.TUNE	preset scan
▲/TUNE+	Tuning up
▼/TUNE-	Tuning down
◀/PRESET-	Preset channel selection
▶/PRESET+	Preset channel selection
BAND	FM/AM switching
0 - 9	Enter number
CLEAR	Clear memory or input data
MEMO	Save preset station number
F.DIRECT	Direct frequency tuning
T.MODE	Auto stereo/monaural switching

- The remote control buttons may not function properly for some Marantz tuners.

Cassette deck operation

Operation buttons	Function
⏮	Fast-rewind
⏭	Fast-forward
■	Stop
▶	Playback
⏸	Pause
CLEAR	Counter reset

Basic connections

NOTE

- Do not plug in the power cord until all connections have been completed.
- When making connections, also refer to the operating instructions of the other components.
- Be sure to connect the left and right channels properly (left with left, right with right).
- Do not bundle power cords with connection cables. Doing so can result in humming or noise.
- Do not turn up the volume without a turntable connected to the PHONO input terminals. Doing so will cause humming or noise.

Preparations

Connecting cables

Select the cables according to the equipment being connected.

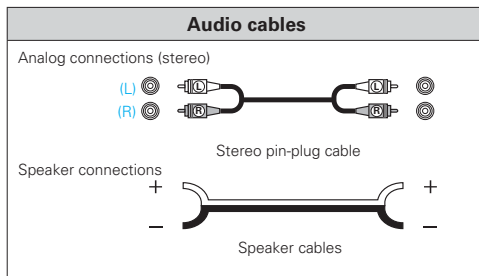

Connecting the audio equipment

Cautions on playing SA(Super Audio) sources:

When regular speakers not compatible with SA sources (DVD Audio discs, Super Audio CDs and other sources, including treble components above the audible range), set the properties of the player (DVD Audio player, Super Audio CD player, etc.) for use with regular speakers (or amplifiers).

The speakers may be damaged if the volume is set too high when playing SA sources. For instructions on player settings, refer to the operating instructions included with the player.

Connecting the speakers

Connecting the speakers cables

Carefully check the left (L) and right (R) channels and + (red) and – (PM-KI-PEARL-LITE(white)) (PM7004(black)) polarities on the speakers being connected to the unit, and be sure to connect the channels and polarities correctly.

1 Peel off about 10 mm of sheathing from the tip of the speaker cable, then either twist the core wire tightly or apply solder to it.



2 Turn the speaker terminal counterclockwise to loosen it.



3 Insert the speaker cable's core wire to all the way into the speaker terminal.



4 Turn the speaker terminal clockwise to tighten it.



NOTE

- Connect the speaker cables so they do not stick out of the speaker terminals. The protection circuit may be activated if the wires touch the rear panel or if the + and – sides touch each other (“Protection circuit”).
- Never touch the speaker terminals while the power supply is connected. Doing so could result in electric shock.

□ Protection circuit

The protection circuit is activated in the following situations:

- If the speaker cable wire touches the rear panel or screws or if the speaker cable wire touches the speaker cable's + and – sides are touching
- If the surrounding temperature is extremely high
- If the inside of the amplifier gets hot to extended use at a high output

If the protection circuit is activated, the speaker output is blocked and the power indicator flashes in red. If this happens, unplug the power cord, then check the connections of the speaker cables and input cables. If the unit becomes very hot, wait for it to cool off and improve the ventilation around it. After doing this, plug the power cord back in.

If the protection circuit is activated even though there are no problems with the ventilation around the unit or in connections, the unit may be damaged. Turn off the power and then contact a Marantz service center.

Connecting the speakers

Speaker connections

- The same signal is output from the SPEAKERS A and B terminals.
- When only one set of speakers is to be connected, use either the SYSTEM A or B terminals.

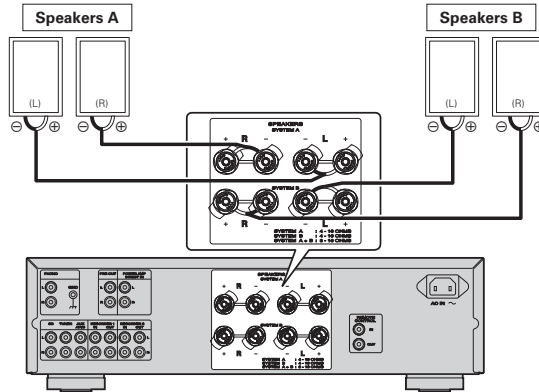

Speaker impedance

Use speakers with impedances within the ranges shown below to suit how they are used.

Speakers used	Impedance
A	4 - 16 Ω
B	4 - 16 Ω
A and B	8 - 16 Ω

Connecting players

A turntable with an MM type cartridge can be connected to this unit. To use an MC cartridge, please install a step-up transformer.

- If humming or other noise is generated when the ground wire is connected, disconnect it.

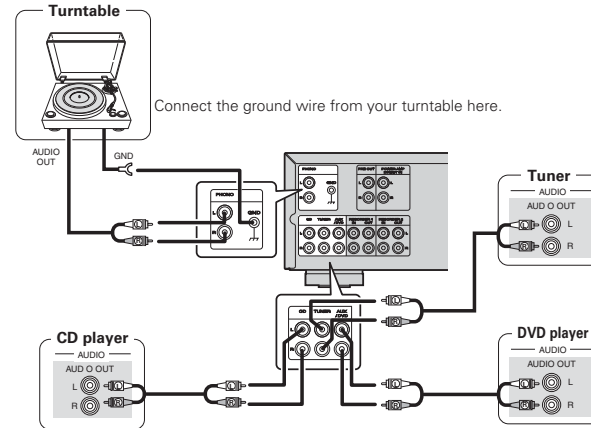

Connecting recorders

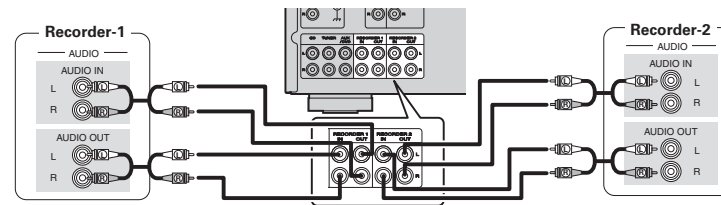

Connecting the power cord

Wait until all connections have been completed before connecting the power cord.

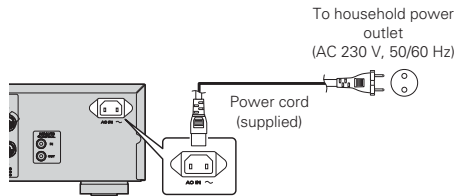

NOTE

- Insert the plugs securely. Loose connections will result in the generation of noise.
- Do not use any cord other than the provided power cord.

Basic operation



Symbols used to indicate buttons in this manual

- Button located on both the main unit and the remote control → **BUTTON**
- Button only on the main unit → **<BUTTON>**
- Button only on the remote control → **[BUTTON]**

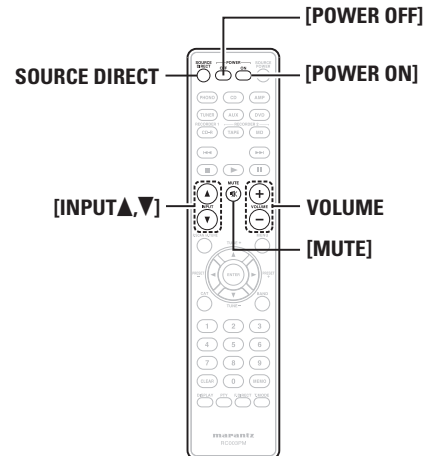
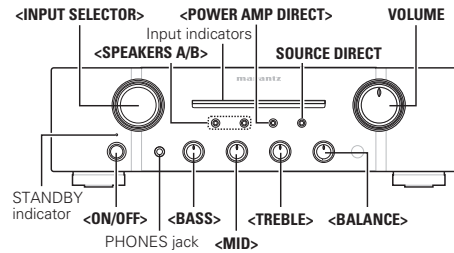

Before use

- 1 Turn the **VOLUME** all the way down.
- 2 Set **<BASS>**, **<MID>**, **<TREBLE>** and **<BALANCE>** to the center positions.

Turning the power on

Press **<ON/OFF>**.

- Power is turned on.
- Input indicator for the selected source lights.
- The unit will be ready to start playback after several seconds.

Turning the power standby

Press **[POWER OFF]**.

- The power is set to the standby mode.
- The STANDBY indicator lights in red.



- Press **[POWER ON]** to turn on power from standby mode.
- You can also turn on power by using either **<INPUT SELECTOR>** from standby mode.

NOTE

Power continues to be supplied to some of the circuitry even when the power is in the standby mode. When leaving home for long periods of time or when going on vacation, either press **<ON/OFF>** to turn off the power, or unplug the power cord from the power outlet.

Turning the power off

Press **<ON/OFF>**.

- Power is turned off.
- All indicators will turn off.

Starting playback

1 Use either <INPUT SELECTOR> or [INPUT ▲,▼] to select an input source you want for playback.

The input indicator for the selected source lights.

[Selectable sources]



- You can also select an input source by pressing the Input selector buttons of the remote control.
- The input source you select is stored in memory even after you turn off power, and the same source is selected when power is turned on again.

2 Press <SPEAKERS A/B> to select the speaker system to be used for playback.

The indicator for the selected speaker system lights.

3 Start playing back the source.

4 Adjust the VOLUME to the desired level.

Adjusting the tone

- <BASS> Adjusts the bass sound.
- <MID> Adjusts the midrange sound.
- <TREBLE> Adjusts the treble sound.
- <BALANCE> Adjusts the left and right output balance.

Direct playback using a source audio component

Since the audio signals bypass the tone control circuits (BASS/MID/TREBLE/BALANCE), the music reproduction is more faithful to the original sound.

Press SOURCE DIRECT.

The SOURCE DIRECT indicator lights.



To adjust the tone, turn off SOURCE DIRECT.

Muting sound

This function mutes the sound by stopping audio output.

Press [MUTE].

The MUTE indicator lights.

- To cancel the mute operation, press the button again.
- You can also cancel the mute operation by operating VOLUME of the remote control.

Using headphone set

Plug headphones into PHONES jack.

- To listen with headphones, turn speaker output OFF.

Adjusting the volume

Adjust the VOLUME to the desired level.

NOTE

To prevent hearing loss, do not raise the volume level excessively when using headphones.

Starting Recording

1 Use either <INPUT SELECTOR> or [INPUT ▲,▼] to select the input source you want to record.

2 Set the recorder to recording mode.

3 Start playback of the source you want to record.

- Recording will start in sync with the playback operation of the source.

Advanced connections

Connecting P.DIRECT connectors

If you use a preamplifier, connect it as shown below, and then you can use this unit as a power amplifier.

To switch the POWER AMP DIRECT mode, press and hold <POWER AMP DIRECT> for at least 3 seconds.

- Switching <POWER AMP DIRECT> "ON", allows the device connected to the Power Amp Direct connector on the rear panel to be played. When ON, the input indicator turns off.
- Switching <POWER AMP DIRECT> "OFF", allows the program source selected using the INPUT SELECTOR knob to be played. When OFF, the input indicator lights up.

For details on operations of the preamplifier, refer to the instruction manual supplied with the preamplifier to be used.

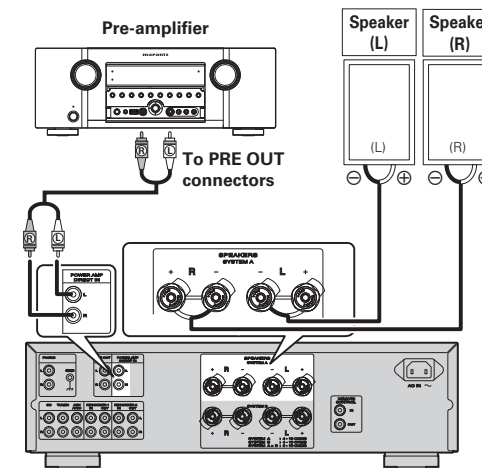

NOTE

- When the POWER AMP DIRECT is "ON", adjustment of the volume, balance and tone on the main unit has no effect. Adjust the volume on the input device.
- When the POWER AMP DIRECT is "ON", the main unit outputs at maximum volume. Check the output level on the input device before playing it and adjust the volume accordingly.

Connecting pre out connectors

If you use a power amplifier, connect it as shown below, and then you can use this unit as a preamplifier.
For connecting speaker systems, refer to the instruction manual supplied with the power amplifier to be used.

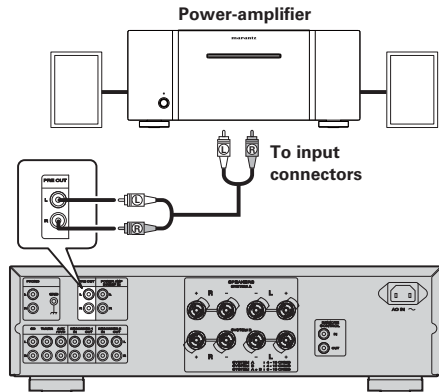

NOTE

- NEVER insert the short-circuiting pin plug into the PRE OUT terminals. Doing so could result in damage.
- Signals are output from the PRE OUT terminals even when using headphones.

Connecting the remote control connectors

When you use this unit connected to Marantz audio components, it sends control signals to operate each component.

Connection

Use the remote connection cable (supplied with a Marantz audio component you want to connect) to connect the REMOTE CONTROL OUT terminal of this unit to the REMOTE CONTROL IN terminal of the component to be connected.

Setting

Set the remote control switch located on the rear panel of the connected audio component to "EXTERNAL" or "EXT." to use this feature.

- This setting will disable remote sensor reception of the connected audio component.
- To operate the connected audio component, point the remote control at the remote sensor of this unit.

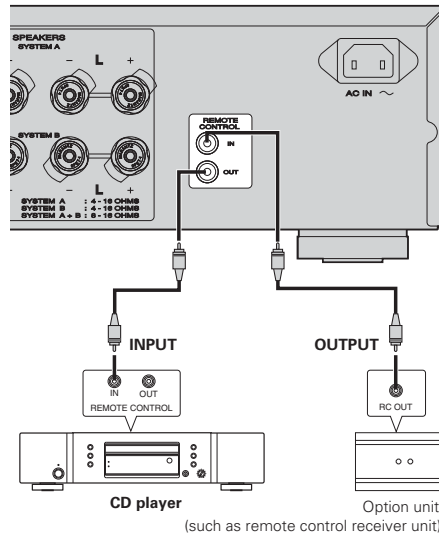

Advanced operations

Setting Auto standby mode

With the Auto standby mode ON, this unit will automatically enter the Auto standby mode after about 30 continuous minutes of no output from the speakers or headphones.

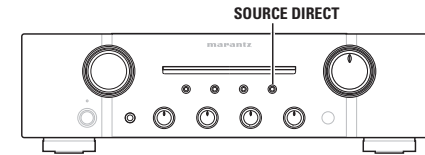

Press and hold <SOURCE DIRECT> for at least 5 seconds.

- Auto standby mode is switched between On and Off.



NOTE

Perform the operation using the buttons on the unit. You cannot perform the operation using [SOURCE DIRECT] on the remote control.



- The default setting for the Auto standby mode is OFF.
- This unit will automatically enter Auto standby mode after about continuous 30 minutes in the following conditions.
 - No output from the selected input source.
 - No operation performed on the remote control.
- No operation of <SPEAKERS A/B>, <POWER AMP DIRECT>, <SOURCE DIRECT> or <INPUT SELECTOR>.

Troubleshooting

If a problem occurs, first check the following:

1. Are the connections correct?
2. Is the unit being operated as described in the owner's manual?
3. Are the other components operating properly?

If this unit does not operate properly, check the items listed in the table below. If the problem persists there may be a malfunction. In that case, disconnect the power immediately and contact your retail outlet.

Symptom	Cause	Countermeasure	Page
Power is not turned on.	<ul style="list-style-type: none"> • The power cord's plug is not plugged in firmly. • The unit is in standby mode. 	<ul style="list-style-type: none"> • Make sure that the power cord is plugged in properly. 	8
		<ul style="list-style-type: none"> • Either turn the INPUT SELECTOR knob of this unit or press POWER ON of the remote control. 	8
	<ul style="list-style-type: none"> • The protection circuit is activated. 	<ul style="list-style-type: none"> • If the STANDBY indicator is blinking, turn off power, wait 1 minute or longer, and turn on power again. 	6
When power is turned on but there is no sound.	<ul style="list-style-type: none"> • The speaker cables are not properly connected. • The input cable is not properly connected. • The INPUT SELECTOR knob setting position is incorrect. • The VOLUME control knob is set to minimum. • The SPEAKERS A/B switches are turned off. 	<ul style="list-style-type: none"> • Make sure the speakers are connected properly. 	7
		<ul style="list-style-type: none"> • Make sure the input cables are connected properly. 	7
		<ul style="list-style-type: none"> • Set the INPUT SELECTOR knob at the correct setting position. 	9
		<ul style="list-style-type: none"> • Use the VOLUME control knob to turn volume up to an appropriate level. 	9
	<ul style="list-style-type: none"> • Turn on the SPEAKERS A/B switch corresponding to the speaker system terminals (SYSTEM A or SYSTEM B) to which the speakers are connected. 	9	
<ul style="list-style-type: none"> • The incorrect SPEAKERS A/B switch is turned on. 	<ul style="list-style-type: none"> • Turn on the SPEAKERS A/B switch corresponding to the speaker system terminals (SYSTEM A or SYSTEM B) to which the speakers are connected. 	9	
<ul style="list-style-type: none"> • The mute function activated. 	<ul style="list-style-type: none"> • If the MUTE indicator is lit, press MUTE on the remote control to cancel muting. 	9	
The volume drops automatically.	<ul style="list-style-type: none"> • The protection circuit is activated. 	<ul style="list-style-type: none"> • Turn off power, wait 1 minute or longer, and turn on power again. 	6
Sound is produced from either one speaker only.	<ul style="list-style-type: none"> • The speaker cables are not properly connected. • The BALANCE control knob setting position is inappropriate. 	<ul style="list-style-type: none"> • Make sure that the speakers are connected properly. 	7
		<ul style="list-style-type: none"> • Set the BALANCE control knob at the appropriate position. 	9
The left and right channels are reversed.	<ul style="list-style-type: none"> • Either the left/right speaker or left/right input cable connections are reversed. 	<ul style="list-style-type: none"> • Make sure that the speakers are connected correctly. 	7
Noise is produced during a record playback.	<ul style="list-style-type: none"> • The ground wire from the turntable is disconnected. • The PHONO input terminals are not properly connected. • A TV set near the turntable is causing the noise. 	<ul style="list-style-type: none"> • Make sure that the PHONO GND terminal is connected properly. 	7
		<ul style="list-style-type: none"> • Make sure that the PHONO input terminal is connected properly. 	7
		<ul style="list-style-type: none"> • Relocate the TV set or turntable in another place. 	-
An audio feedback occurs when you turn up the volume during a record playback.	<ul style="list-style-type: none"> • The turntable and speakers are too close to each other. • The turntable is placed on a rack or floor that vibrates easily. 	<ul style="list-style-type: none"> • Install the speakers as far away from the turntable as possible. 	-
		<ul style="list-style-type: none"> • If the turntable is not supplied with an insulating pad, use insulating pad available in the market. 	-
The unit does not function when a remote control button is pressed.	<ul style="list-style-type: none"> • Batteries are low. • You are operating the remote control outside of the specified range. 	<ul style="list-style-type: none"> • Replace with new batteries. 	3
		<ul style="list-style-type: none"> • Operate within the specified range. 	3
	<ul style="list-style-type: none"> • There is an obstacle between the main unit and remote control. 	<ul style="list-style-type: none"> • Remove the obstacle. 	3
	<ul style="list-style-type: none"> • You have pressed the wrong button. 	<ul style="list-style-type: none"> • Press the correct button. 	5
	<ul style="list-style-type: none"> • Batteries are not inserted in the proper direction as indicated by polarity markers (⊕ and ⊖) in the battery compartment. 	<ul style="list-style-type: none"> • Insert the batteries in the proper direction in accordance with the polarity markers in the battery compartment. 	3

- Getting started
- Basic connections
- Basic operation
- Advanced connections
- Advanced operation
- Troubleshooting
- Specifications
- Explanation terms
- Index

Specifications

<ul style="list-style-type: none"> • Power output (20 Hz – 20 kHz simultaneous drive of both channels): 	70 W x 2 (8 Ω load) 100 W x 2 (4 Ω load)
<ul style="list-style-type: none"> • Total harmonic distortion (20Hz – 20kHz simultaneous drive of both channels, 8Ω load): 	0.02%
<ul style="list-style-type: none"> • Output band width (8Ω load, 0.05%): 	5Hz – 60kHz
<ul style="list-style-type: none"> • Frequency response (CD, 1W, 8Ω load): 	5Hz – 100kHz ±3dB
<ul style="list-style-type: none"> • Dumping factor (8Ω load, 20Hz – 20kHz): 	100
<ul style="list-style-type: none"> • Input sensitivity/Input impedance PHONO (MM): CD, TUNER, AUX/DVD, RECORDER: MAIN IN 	2mV/47kΩ 200mV/20kΩ 1.6V/15kΩ
<ul style="list-style-type: none"> • Output voltage/Output impedance PRE OUT 	1.6V/600Ω
<ul style="list-style-type: none"> • Maximum allowable PHONO input level (1kHz) MM 	100mV ±0.5dB
<ul style="list-style-type: none"> • RIAA deviation (20Hz ~ 20kHz) 	
<ul style="list-style-type: none"> • S/N (IHF-A, 8Ω load) PHONO (MM) (PM-KI-PEARL-LITE) (PM7004) CD, TUNER, AUX/DVD, RECORDER (PM-KI-PEARL-LITE) (PM7004) POWER AMP DIRECT IN . 	87dB (5mV input, 1W output) 85dB (5mV input, 1W output) 106dB (2V input, Rated output) 104dB (2V input, Rated output) 125dB (Rated output)
<ul style="list-style-type: none"> • Tone control Bass (50Hz) Mid (900Hz) Treble (15kHz) 	±10dB ±6dB ±10dB
<ul style="list-style-type: none"> • Power requirement 	AC 230V 50/60Hz
<ul style="list-style-type: none"> • Power consumption (EN60065) Standby power consumption 	200W 0.3W
<ul style="list-style-type: none"> • Weight PM-KI-PEARL-LITE PM7004 	11.2kg 10.5kg

For the purpose of improvement, the specifications and design are subject to change without notice.

Explanation terms

P

Protection Circuit

This is a function to prevent damage to components within the power supply when an abnormality such as an overload or excess voltage occurs for any reason.

In this unit, the STANDBY indicator blinks and the unit enters standby mode when an abnormality occurs.

S

Speaker impedance

This is certain-rated resistance of the speaker set to an alternating current and expressed in ohms. The smaller the impedance, the greater the output. However, load on the amplifier is increased. Use speakers whose impedance is supported by this unit.

Index

A

Adjusting the tone	9
Adjusting the volume	9
Auto standby mode	10

B

BALANCE	4, 8
BASS	4, 8
Batteries	3
Before use	8

C

Connection	
Connecting cables	6
Connecting players	7
Connecting recorders	7
Connecting the speakers	6, 7

I

INPUT SELECTOR	4, 8
----------------------	------

M

MID	4, 8
Mute	4, 8

P

POWER AMP DIRECT	4, 9
Power cord	8
PRE OUT	4, 10
Protection circuit	6, 12

R

Remote control	3, 5, 10
----------------------	----------

S

SOURCE DIRECT	4, 8
Speaker cables	6, 7
Stereo pin-plug cable	6

T

TREBLE	4, 8
--------------	------

V

VOLUME	4, 8
--------------	------

• PM-KI-PEARL-LITE (unit: mm)

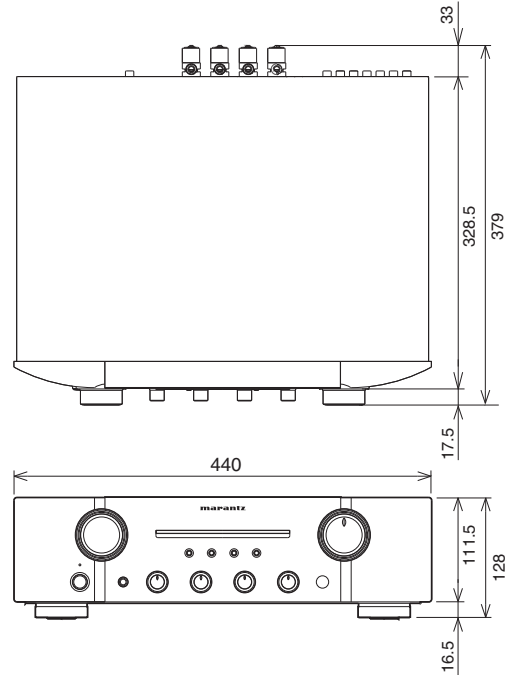

• PM7004 (unit: mm)

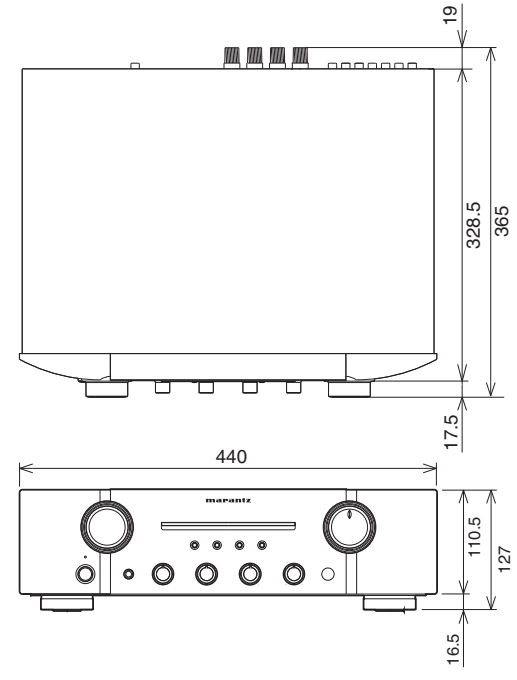

www.marantz.com

You can find your nearest authorized distributor or dealer on our website.

marantz[®] is a registered trademark.